

Version: 02/16

company: _____ contact: _____
 area _____ department: _____
 code/area: _____
 street: _____ project: _____
 phone: _____ date: _____

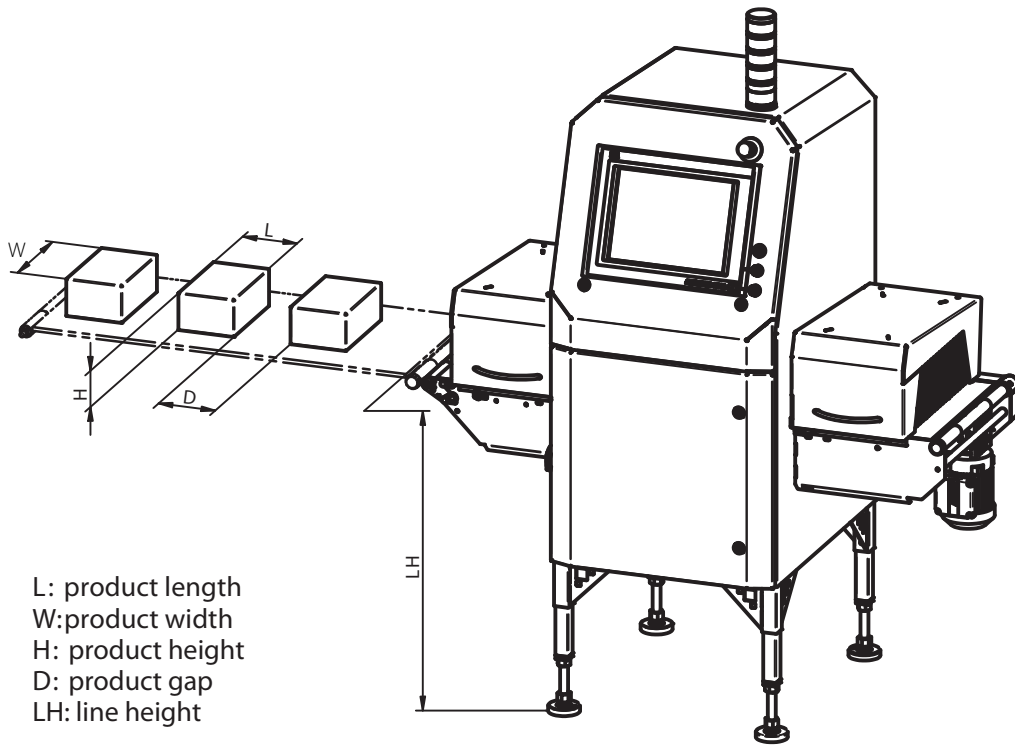

line details

line - ID _____

line height LH (mm) _____

ambient temperature (°C) +5°C to +28°C +5°C to +40°C other: _____

rejection device no (belt stop) pusher air jet flap



product details (fill in multiple if necessary!)

product description	<input type="text"/>	<input type="text"/>	<input type="text"/>
packaging material	<input type="text"/>	<input type="text"/>	<input type="text"/>
product dimensions (mm)	L: <input type="text"/> W: <input type="text"/> H: <input type="text"/>	L: <input type="text"/> W: <input type="text"/> H: <input type="text"/>	L: <input type="text"/> W: <input type="text"/> H: <input type="text"/>
product gap D (mm)	<input type="text"/>	<input type="text"/>	<input type="text"/>
product temperature (°C)	<input type="text"/>	<input type="text"/>	<input type="text"/>
weight (g)	<input type="text"/>	<input type="text"/>	<input type="text"/>
format (e.g. 2.3)	<input type="text"/>	<input type="text"/>	<input type="text"/>
format dimensions (mm)	L: <input type="text"/> W: <input type="text"/> H: <input type="text"/>	L: <input type="text"/> W: <input type="text"/> H: <input type="text"/>	L: <input type="text"/> W: <input type="text"/> H: <input type="text"/>
throughput (pcs. / min.)	<input type="text"/>	<input type="text"/>	<input type="text"/>
misc/drawings	<input type="text"/>		